

Section 12 Troubleshooting

Problems	Cause	Solution	
Sensor does not operate	Sensor Connector	Tighten connector or reconnect	
	Power Supply	Check that the power supply is properly connected.	
Sensor intermittently becomes state of detection	Sensor is very dusty or covered in water drops, etc.	Clean the sensor (do not use thinner or alcohol to clean sensor)	
	Sensitivity too low	Turn up sensitivity	
	Detection pattern in the wrong position	Alter the detection pattern by changing sensor angle, and/or pattern width adjustments	
Sensor becomes state of detection by itself	Sensitivity too high	Turn down Sensitivity.	
	Another sensor is too close by	Change the frequency to each sensor.	
	Sensor detects the door movement	If the indicator LED is an Orange color, adjust the pattern depth angle away from the door	
	There is a cloth mat in the monitored area.	Reactivate the sensor and wait for 10 seconds.	
	Detection pattern too far in front of the door, detecting people passing by	Adjust the detection pattern - move it closer to the door	
	The condition of the monitored area is varying. • Dusty / Dirty • Snow	The condition of the monitored area can change due to heavy dust or dirty, heavy snow or footprints being left in fresh snow, this will cause the malfunction sometimes. Set the "Presence Timer" to a short times. Refer to Section 7.	
The door kept open, although there is no object in the detection area.	Internal error (Green/Red LED blinks alternately)	Fast blink	Please replace the sensor (Refer to Section 11)
		Slow blink	Low reflection error or Test line disconnection (Refer to Section 7, Section 11)

Section 13 Technical Data

Model Name	HR94D1-C1 Motion & Presence Sensor	Power Consumption	AC24V-2.8VA, AC12V-1.8VA DC24V-60mA, DC12V-100mA
Detection Method	Active Infrared Detection	Output Contact	Open collector 7.5[mA](Max) Resistor Load
Maximum Installed Height	2.7m (9ft.)		DIP SW #4 : OFF Normally Drive (Normally Close) Open on Detection
Width Detection Adjustment	Area Mask (wide or narrow)	DIP SW #4 : ON Drive on Detection (Close on Detection)	Opto coupler(NPN) Voltage:55 [VDC] Max. Current:50 [mA] Max. Dark Current : 100 [nA] Max. (Resistance load)
Depth Detection Adjustment	The sensor body angle (0° to 5° in 3 steps)	Test Input	Non-Test : DC12 to 24 V 6 [mA] Max. Test : Open @ 24 [VDC]
Sensitivity Adjustment	Potentiometer	Operating Temperature	-20 °C to 60 °C (-4 °F to 140 °F)
Noise Prevention	DIP Switch #7 (Normal or Snow Mode)	Operating humidity	Below 80%
Cross Interference	DIP Switch #5, #6 (One of 4 frequencies)	IP Rate	IP54
Output Holding Time	Approx. 0.5 seconds	Category	2, performance level C for presence detection according to EN ISO 13849-1:2008
Response Time	0.1 ~ 0.2 sec	Weight	0.190kg, (0.42lbs.)
Presence Timer	DIP Switch #1, #2 (2, 15, 60, 180 seconds)	Accessories	Cable : 2.5m (8ft.) Mounting Screw (2pcs) Mounting Template User Manual
Test Mode	DIP Switch #3 (Normal or Ignore Low Ref)		
LED Indication	GREEN - Standby RED - Detecting ORANGE - The detection area is too close to the door. Green/Red blinks alternately - Internal error		
Power Supply	12 to 24V AC or DC +/-10% Red & Black (Nonpole)		

HR94D1-C1 EC DECLARATION OF CONFORMITY

Compiler of Technical File (EC Community) David Morgan Hotron Ireland Ltd 26 Dublin Street, Carlow, Ireland Ph: +353-(0)59-9140345 Fax: +353-(0)59-9140543		Description of Product: HR94D1-C1 is designed to monitor the side screen of the automatic door. Technology used is Active Infrared Technology
Directives Fulfilled: DIRECTIVE 2006/42/EC Powered pedestrian doors Part 1: Product requirements chapter 5.7.4 DIN 18650-1:2005 Industrial, commercial and garage doors and gates - safety devices for power operated doors and gates - Requirements and test methods EN12978:2003 Functional safety of electrical/electronic/programmable electronic safety-related systems EN62061:2005 Safety of machinery - Safety-related parts of control systems. EN ISO 13849-1:2008		
Above EC Type Directives Certified by: TUV NORD CERT GmbH 30519 Hannover, Germany Identification No: 0044	Harmonised Standards Used: EN ISO 13849-1:2008	Declaration made by Kaoru Musya General Manager Date 25 th November 2009 Location of Declaration Honda Electron Co., LTD. 1-23-19 Asahi-Cho, Machida-City, Tokyo, Japan
	Other Technical Standards Used: DIN 18650-1:2005	

HOTRON
HOTRON CO., LTD.

Manufacturer
HOTRON CO., LTD.
1-11-26 Hyakunin-Cho,
Shinjuku-Ku, Tokyo, Japan
Phone: +81-(0)3-5330-9221
Fax: +81-(0)3-5330-9222
URL: http://www.hotron.com

SALES Europe
Hotron Ireland Ltd.
26 Dublin Street (2nd Floor),
Carlow, Ireland
Phone: +353-(0)59-9140345
Fax: +353-(0)59-9140543
URL: http://www.hotron.com

HOTRON HR94D1-C1 User Manual (Original)

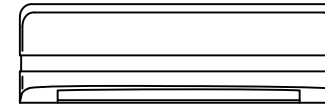

COMPLIED STANDARDS
DIN18650-1:2005
EN 12978:2003



Active Infrared Motion & Presence Sensor for Side Screen Automatic Door Control in accordance with EN12978-2003
We would like to extend our thanks to you for purchasing this sensor. We at Hotron is committed to providing you with quality products and excellent customer service. Before installing this sensor, please read the following instructions carefully:

WARNING This symbol indicates extremely dangerous situations. If users ignore this symbol and handle the device the wrong way, serious injury or death can result.

CAUTION This symbol indicates dangerous situation. If users ignore this symbol and handle the device the wrong way, injury or damage to the equipment can result.

Install the sensor in accordance with laws and standards of the country where it is installed. Only an installer or service engineer can change the sensor setting. The changed settings and the date shall be recorded in the maintenance book.

Section 1 General Description / Features

The HR94D1-C1 is a microprocessor controlled active infrared motion and presence detector. It is designed to monitor the side screen of the automatic door. It provides presence detection close to the door on single slide and bi-parting sliding doors.

- Detection area of the sensor is adjustable.
- 'Snow mode' prevents malfunction due to falling snow, falling leaves, insects, etc.
- Microprocessor provides programmable Presence Timer (180, 60, 15, or 2 seconds).
- Test input is acceptable for sensor monitoring.

Section 2 Parts Identification

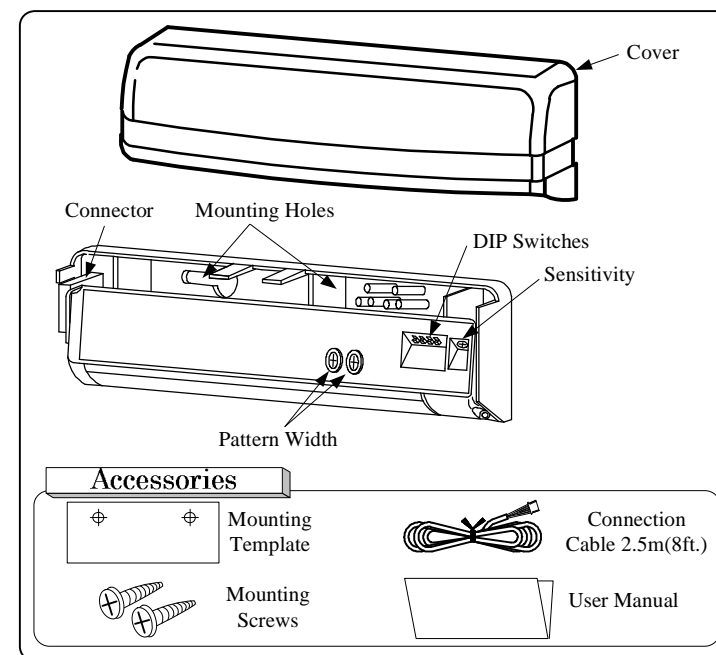

Section 3 External Dimensions

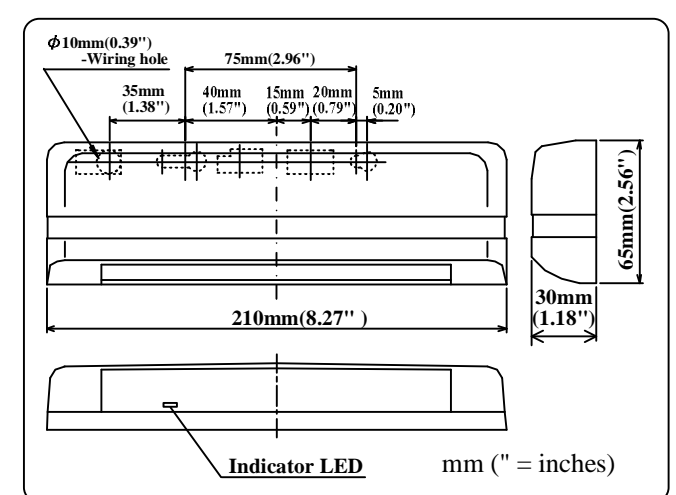

Section 4 Mounting Information **CAUTION**

- 1 Mount lower than 2.7m (9ft.).
- 2 No moving objects in the detection zone.
- 3 Do not mount where rain or snow will fall directly on unit, and ensure no accumulation of snow or water on the floor.
- 4 Do not mount in a place where reflection of sunlight will shine on unit.
- 5 Do not mount in a humid or steamy environment.
- 6 Do not mount five devices in proximity to each other. When using from 2 to 4 devices in proximity, use different frequency settings as shown. (Maximum 4 sensors)

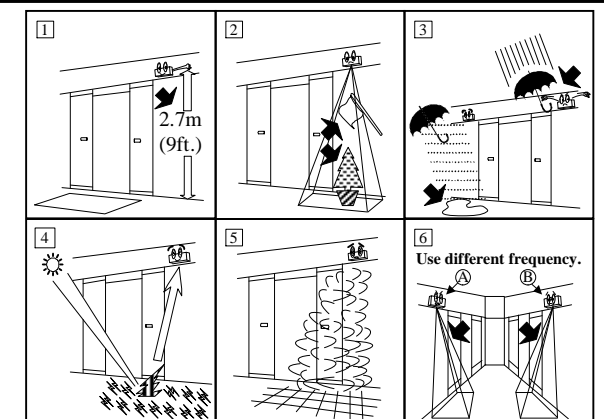

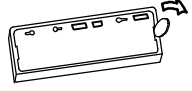
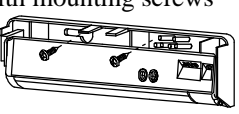

Section 5 Mounting and Wiring

WARNING ⚠️ Drilling may cause Electric shock! When drilling, pay attention to wires inside door hardware.

- Using the mounting template provided, drill mounting and wire holes. 
- Remove cover using a coin. 
- Fasten unit with mounting screws provided. 
- Connect wiring. Push connector.

Red & Black	= Power [Nonpole]
White	= Output [Collector]
Blue	= Output [Emitter]
Brown	= Test input [Test-P]
Yellow	= Test input [Test-N]



- Place connector in holder. 
- Set desired sensor parameters as noted in Sections 7 & 9.

Section 7. DIP Switch Settings
 Section 9. Adjusting Detection Pattern
- Place cover on sensor and clean the sensor. 

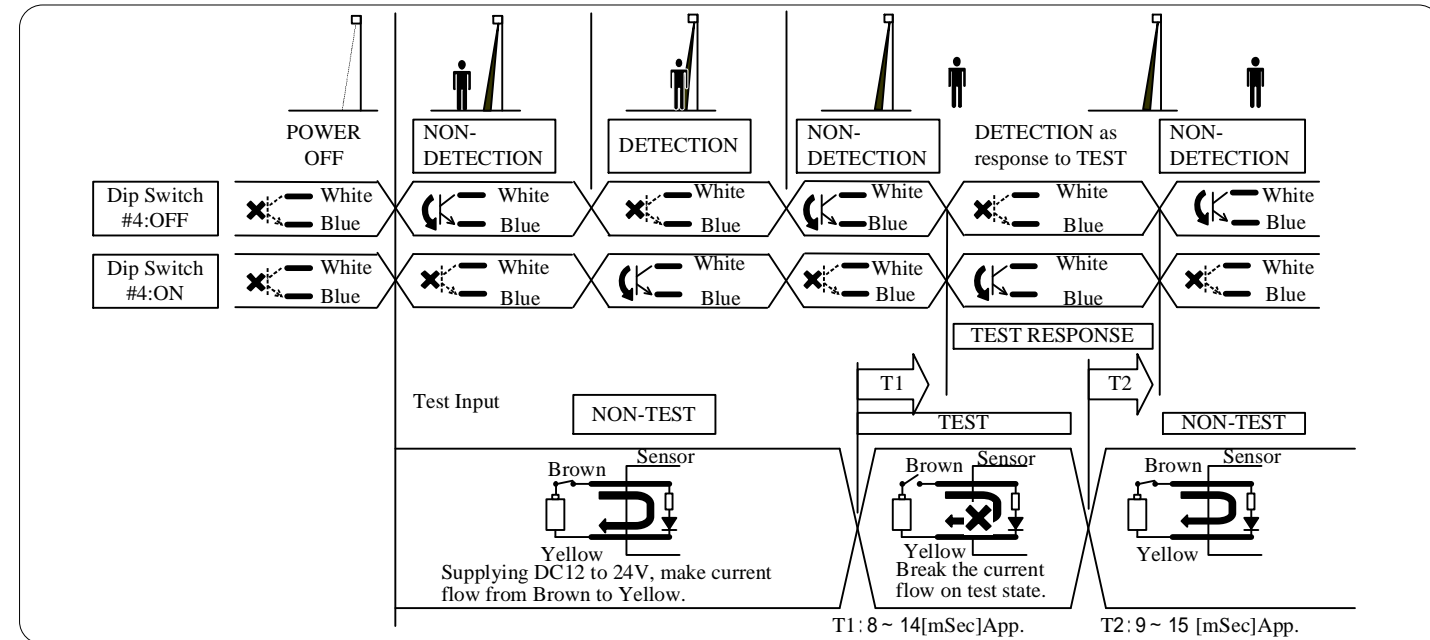
Section 6 Wire Information & Timing Chart of events

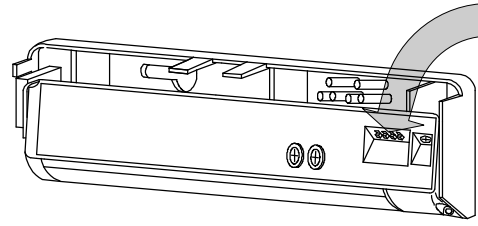

Section 7 Dip Switch Setting



Presence Timer	Test Mode	Output	Frequency	Monitor Mode
2 Sec	Normal	N.C. (DRIVE)	A	Normal
15 Sec	Low REF.	N.O.	B	Snow
60 Sec			C	
180 Sec			D	
1 2	3	4	5 6	7

8 : Not used

- Presence Timer** : The HR94D1-C1 will detect a stationary object only for the time period set by the Presence Timer. The timer will reset and begin if any movement is detected.
 Set the timer to 60sec. or more to comply with DIN18650.
- Test Mode** : When the reflection from the floor is very low, The HR94D1-C1 regards the state as error state. (Default setting) To ignore this error, set this switch "ON". (Refer to Section 11)
 Set to "Normal" to comply with DIN18650.
- Output** : Output logic is defined by this switch. In the N.C. , Opt-Coupler will be driven in the state of non-detection.
- Frequency** : When more than two sensors are used in close proximity to each other, select different frequency setting for each sensors to prevent interference.
 (A + B + C + D = Maximum 4 sensors)
- Monitor Mode** : A Snow Mode is available using switch 7. Snow Mode should only be used in environments with heavy snowfall or other extreme conditions.

Section 8 Applying Power

BEFORE APPLYING POWER, READ AND FOLLOW THESE INSTRUCTIONS:
 When power is applied, the sensor will read and store the environmental optical parameters. This is necessary for Presence Detection to work properly.

- CLEAR THE AREA OF ANY UNNECESSARY OBJECTS.
- APPLY POWER.
- WALK AWAY FROM THE DETECTION AREA immediately.
- DO NOT ENTER DETECTION AREA for 10 SECONDS while the "learning procedure" for Presence detection is carried out.

If the sensor can see moving objects during the "learning procedure", the sensor will not proceed to presence detection.

CAUTION ⚠️ Please DISCONNECT POWER TO THE SENSOR, when carrying out the following work. AFTER THE TASK, APPLY POWER AGAIN.

- When the floor condition change (woolen/rubber).
- Adjusting pattern or sensitivity.

Section 9 Adjusting Detection Pattern

Adjust the detection pattern according to the following diagrams:

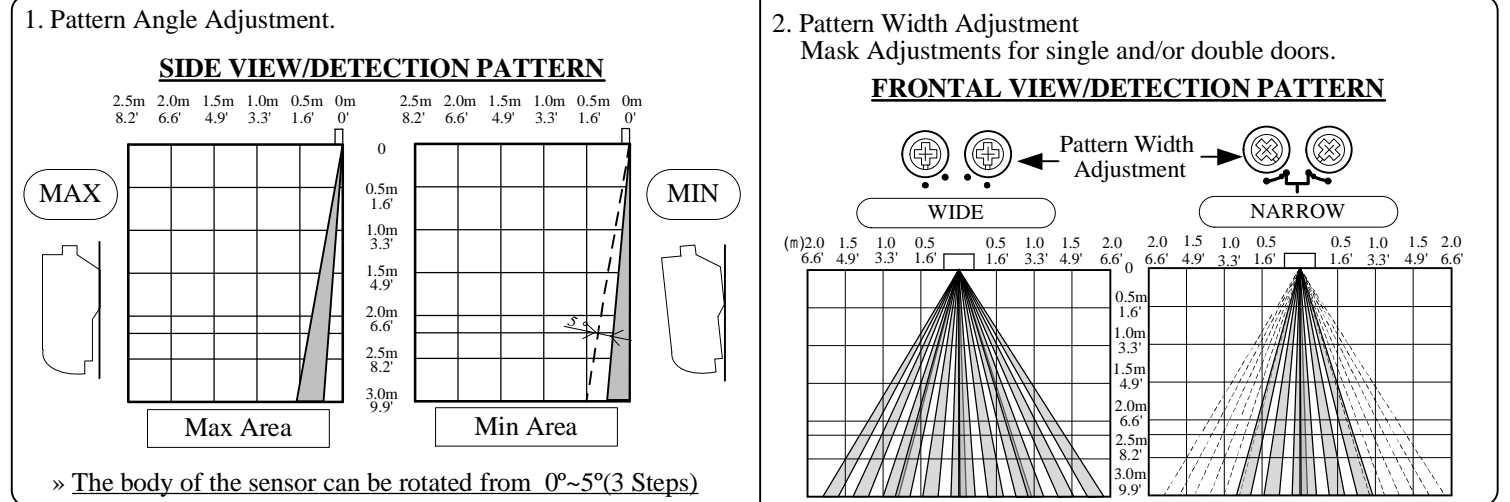

Section 10 Verification of Operation

- After mounting, setting parameters and applying power, walk test unit to verify detection area.
- If the door does not operate properly, recheck the dip switch settings and pattern adjustments.
- After rechecking, if there is still a problem, adjust the sensitivity.

» Adjust high (clockwise) to increase sensitivity.
 » Adjust low (counter-clockwise) to decrease sensitivity.

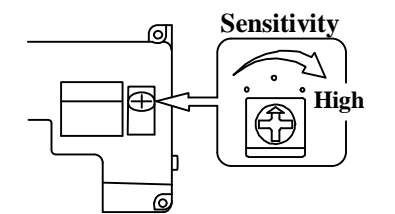

CAUTION ⚠️ As the detection area is variable depending on clothes, floor material and sensitivity adjustment, please confirm that the detection area demanded in DIN18650 is secured after adjustment.

Section 11 Self-Test Error

When the sensor has the self-test error, the green/red LED blinks alternately. The blinking cycle is different, according to the kinds of the error as follows.

LED	Cause	Solution	Response to TEST	Output on Error State
Fast Blink (Green/Red) Green Red	Internal error	Please replace the sensor.	No Response	DIP Switch #4 : OFF
Slow Blink (Green/Red) Green Red	Low reflection level	Set the sensitivity to maximum, and then reactivate the sensor. If the error continues, set DIP Switch #3 "ON" .		DIP Switch #4 : ON
Slow Blink (Red/Red/Green) Green Red	Test line disconnection	Please confirm the connection of the test line.		